



education

Department:
Education
REPUBLIC OF SOUTH AFRICA

**NATIONAL
SENIOR CERTIFICATE**

GRADE 12

ELECTRICAL TECHNOLOGY

MEMORANDUM

EXEMPLAR 2008

MARKS: 200

TIME: 3 hours

This memorandum consists of 16 pages.

INSTRUCTIONS:

- Answer ALL the questions.
- Sketches and diagrams must be large, neat and fully labelled.
- All calculations must be shown, and correct to two decimal places.
- Answers must be clearly numbered.
- A formula sheet is provided at the end of the paper.
- Non-programmable calculators may be used.

QUESTION 1
TECHNOLOGY, SOCIETY AND THE ENVIRONMENT

- 1.1 Culture is generally the way people do things, e.g the way we dress, travel, communicate etc. so the development of technology over time has drastically changed the way we communicate , travel etc. The examples can include the following: (4)
- we no longer use donkeys and horse carts, trains and aeroplanes which are faster ✓
 - the development of telecommunication systems such as landlines phones and mobile phones have changed the old way of communication using letters. ✓
 - The way we dress and what we dress has been changed by designs of new types of clothes. ✓
 - Food technology has also changed the type of food and the way we eat. ✓
- 1.2 (4)
- communication✓
 - marketing skills✓
 - time management skills✓
 - financial skills ✓
- ANY TWO FROM ABOVE
- 1.3 Make sure that you do not come into contact with blood ✓✓ (2)
- [10]**

QUESTION 2
TECHNOLOGICAL PROCESS

- 2.1 (5)
- the designed product should be operated by foot✓
 - the designed product should be able to open pages of a book✓
 - the product should be fitted on the table✓
 - the foot-operated device should be fixed on the ground, so as to avoid shifting around ✓
 - the product should be mechanically operated in order to open the pages of a book✓
- ANY RELEVANT ANSWER NOT MENTIONED IS ACCEPTED
- 2.2 (3)
- Observation: this include analyzing the product in order to understand its design, and jotting down notes about the product✓
 - Interviews: this is about finding out from the target audience, whether the

product satisfy their needs✓

- Questionnaires survey: to find out how many target audience are satisfied with the product✓

- 2.3
- Overhead projector✓
 - Computer✓
 - Photocopies
 - Audio-visual
 - Graphic charts
- (Any **TWO** correct answers)
- (2)
- [10]**

QUESTION 3 OCCUPATIONAL HEALTH AND SAFETY

- 3.1 Any unsafe condition relating to the electrical technology workshop: e.g. (2)
- No CO2 Fire extinguisher in the workshop✓
 - No Earth Leakage protection installed in the workshop✓
 - Live Exposed electrical connections are present in the workshop.
- 3.2
- 3.2.1
- Beware of wet areas and moisture ✓✓
 - To avoid shock use electric tools only if the floor and surroundings are dry✓✓
 - Always disconnect the power from a tool when not in use
- (4)
- 3.2.2
- Check for cracks on the cable ✓✓
 - The cable must be earthed or double insulated ✓✓
 - You must not stand in a damp area when working with portable electrical instrument
 - Check damage to the plug
 - Check for non-standard joints
- (4)
- [10]**

QUESTION 4
THREE-PHASE AC GENERATION

4.1

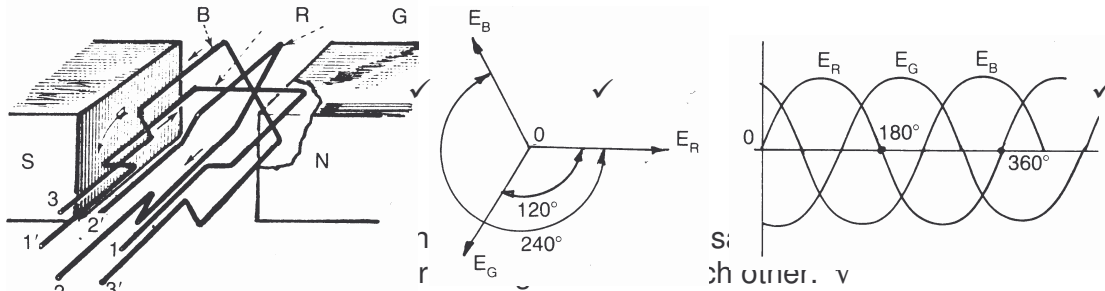

- The coils are rotating within the same field as shown on the diagram. ✓
- With the armature rotating anti-clockwise the three e.m.f.'s generated will be as in the diagram. ✓ (Any two)

(5)

4.2.1

$$V_{Ph} = \frac{V_L}{\sqrt{3}} \quad (\Leftarrow = \frac{1}{2} \text{ Mark})$$

$$= \frac{380}{\sqrt{3}} \quad \Leftarrow$$

$$= 219.4 \text{ V} \quad \checkmark$$

(2)

4.2.2

$$I_{Ph} = \frac{V_{Ph}}{R_{Ph}} \quad \Leftarrow$$

$$= \frac{219.4}{50} \quad \Leftarrow$$

$$= 4.39 \text{ A} \quad \checkmark$$

(2)

4.2.3

$$I_L = I_{Ph} \quad \checkmark$$

$$= 4.39 \text{ A}$$

(1)

QUESTION 5
R, L, C CIRCUITS

- 5.1.1 Inductive reactance✓ (1)
- 5.1.2 Capacitive reactance✓ (1)
- 5.2.1 (↔ = ½ Mark) (6)
- $$X_L = 2\pi FL$$
- $$= 2\pi \times 50 \times 0.14$$
- $$= 43.98\Omega$$
- ↔
↔
✓
- $$X_C = \frac{1}{2\pi FC}$$
- $$= \frac{1}{2\pi \times 50 \times 49 \times 10^{-6}}$$
- $$= 64.96\Omega$$
- ↔
↔
✓
- $$Z = \sqrt{R^2 + (X_L - X_C)^2}$$
- $$= \sqrt{40^2 + (64.96 - 43.98)^2}$$
- $$= 45.17\Omega$$
- ↔
↔
✓
- 5.2.2 (2)
- $$I = \frac{V}{Z}$$
- $$= \frac{220}{45.17}$$
- $$= 4.87A$$
- ↔
↔
✓
- 5.2.3 (4)
- $$Z_L = \sqrt{R^2 + X_L^2}$$
- $$= \sqrt{40^2 + 43.98^2}$$
- $$= 59.45\Omega$$
- ↔
↔
✓
- $$V_{ZL} = IZ_L$$
- $$= 4.87 \times 59.45$$
- $$= 289.52V$$
- ↔
↔
✓

5.3.1 $I_R = \frac{V}{R}$ \checkmark ($\checkmark = \frac{1}{2}$ Mark) (8)

$$= \frac{220}{40}$$

$$= 5.5A$$

$I_L = \frac{V}{X_L}$ \checkmark

$$= \frac{220}{37.7}$$

$$= 5.83A$$

$I_C = \frac{V}{X_C}$ \checkmark

$$= \frac{220}{21.22}$$

$$= 10.37A$$

$$\therefore I_T = \sqrt{I_R^2 + (I_C - I_L)^2}$$

$$= \sqrt{5.5^2 + (10.37 - 5.83)^2}$$

$$= 7.13A$$

5.3.2 $\cos\theta = \frac{I_R}{I_T}$ \checkmark (4)

$$= \frac{5.5}{7.13}$$

$$= 0.77$$

$\therefore \theta = \cos^{-1}0.77$ \checkmark

$$= 39.52^\circ \text{ Leading}$$
 \checkmark

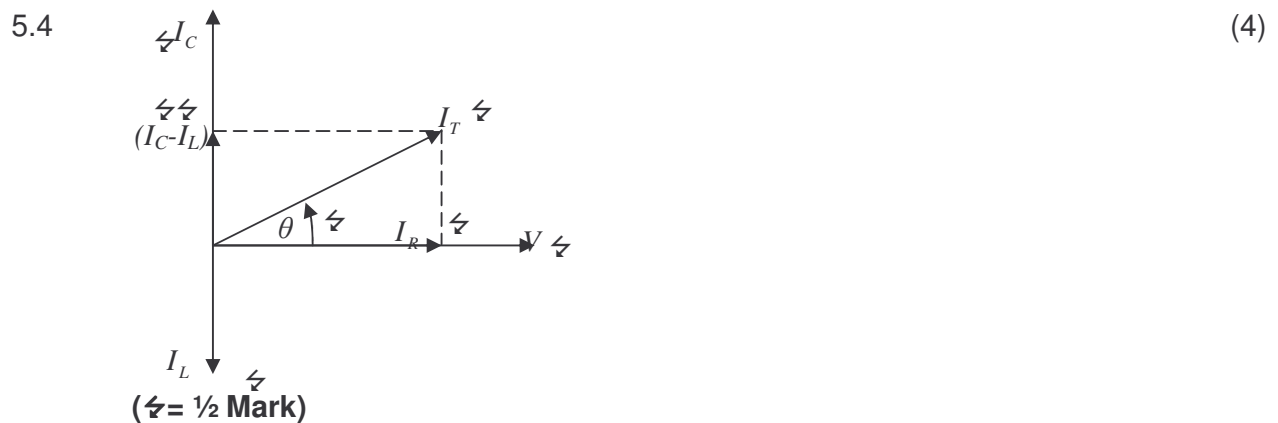

QUESTION 6
SWITCHING AND CONTROL CIRCUITS

- 6.1
- An AC input is applied to the circuit consisting of R_i , R_v and C_1 via the lamp ✓
 - During the positive half of the cycle C_1 will charge to a positive voltage via the resistors. ✓
 - After a period, determined by the time constant of C_1 multiplied by the value of $R_1 + R_i$, the voltage over the capacitor reaches the value at which the DIAC triggers. This is usually around 30V. The result is that the gate of the TRIAC is triggered and the TRIAC switches on. ✓✓
 - The TRIAC will now stay switched on for the remainder of the positive cycle, whether or not a signal is applied to the gate of the TRIAC or not. ✓✓
 - When the TRIAC switches on the internal resistance decreases rapidly causing C_1 to discharge through it and simultaneously current flows through the TRIAC switching on the lamp. ✓✓
 - The TRIAC will remain switched on up to the end of the positive cycle, when it will switch off due to a lack of current holding it switched on when the input voltage goes through zero. ✓
 - During the negative half cycle C_1 will be charged in the opposite direction (negative) ✓ and the whole process repeats itself, ✓ with the polarity being negative in this instance. The DIAC is able to switch to exactly the same voltage value in both directions thus allowing for the negative gate pulse to be applied to the TRIAC which in turn also conducts in both directions thus enabling it to regulate AC. ✓
 - By adjusting the value of R_v , the time constant $T = (R_i + R_v) \times C_1$ is adjusted. This in return regulates the time the TRIAC is switched on during each half cycle. The longer the TRIAC stays switched on, the brighter the Lamp will light up and visa versa. ✓
- (13)
- 6.2
- A DIAC can be connected into a circuit in any direction
 - A DIAC acts as a triggering device. ✓
 - A DIAC becomes conductive at a very specific voltage value, which is the same for both directions. ✓
 - If a rising voltage is applied to a DIAC it acts as like an open switch or Diode in reverse bias. ✓
 - When the trigger voltage is reached i.e. 35 Volt, the internal resistance of the DIAC breaks down, thus allowing a trigger pulse to flow through the DIAC, in the same way, avalanche breakthrough is achieved in Zener Diodes. ✓
 - As soon as the current through the DIAC falls below the holding current (the minimum current needed to keep the diode biased) the DIAC will cease to conduct. ✓
- (6)

6.3

(4)

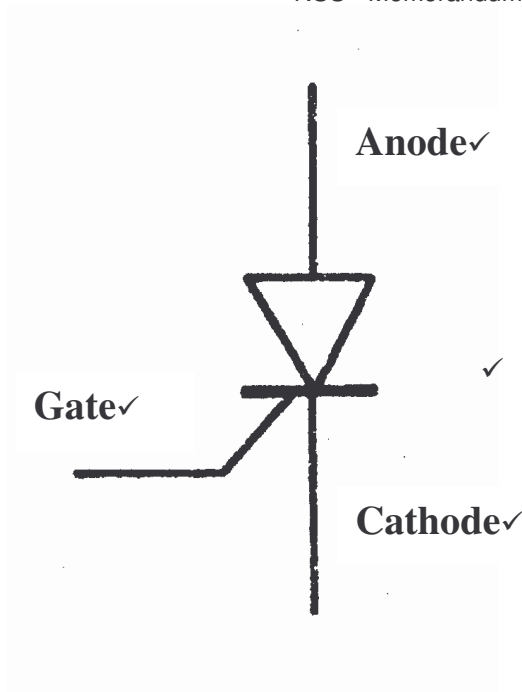

- 6.4 The Thyristor can only conduct for a half cycle as compared to the TRIAC that is able to conduct in both directions and thus for a full-cycle. ✓✓

(2)

[25]

QUESTION 7 AMPLIFIERS

- 7.1 **Answer:** Making use of a split power supply allows the operational amplifiers output to swing from positive to negative with respect to ground. ✓✓

(2)

Ref: FW Hughes, Op-Amp Handbook, ISBN 0-13-637315-1

- 7.2 **Answer:** A differential amplifier consists of two identical sections each having input terminals. Two output terminals or a single output terminal common to both amplifiers is provided. Ground is common to both sections. The differential amplifier only amplifies the difference in signal between the two input signals. This amplified signal is represented on the output/outputs. ✓✓

(2)

Ref: RP Turner, Illustrated Dictionary of Electronics, ISBN: 0-8306-1366-8

7.3 Answer: (3)

- Open Circuit Voltage Gain is infinite. ✓
- Input impedance is infinite. ✓
- Output Impedance is zero ✓
- Offset voltage is zero with no inputs attached
- Common Mode Rejection Ratio is infinite.
- Frequency response is infinite
- Slew rate is immediate or zero.

(Any three)

Ref: C du Preez et al, Technika Eletrical 3. ISBN-0-620-08230-5
R. Boylestadt et al, Electronic Devices & Circuit Theory, ISBN: 0-13-249517-1

7.4 Positive Feedback – When the out put of a circuit is fed back to the input of the same circuit in phase with the input signal, the resultant will be ever increasing output. The result could be distortion or overloading of the circuit. ✓ (4)

Example: When the microphone of an audio amplifier is held close to the speaker positive feedback causes the amplifier to “whistle” causing great discomfort to the human ear. ✓

Negative feedback – When the output of a circuit is fed back to the input of the same circuit out of phase with the input, the result is that the output signal becomes smaller and may even disappear. ✓

Example: Negative feedback is utilized in amplifiers to obtain volume control and gain control such as is used in the oscilloscope. ✓

7.5

7.5.1 Non inverting amplifier mode. ✓ (1)

7.5.2 This would not be a good audio amplifier because the output waveform is not an exact replica of the input waveform. The wave has been distorted slightly. ✓✓ (2)

7.5.3 $A_v = \frac{R_f}{R_{in}} + 1$ ⇐ (⇐ = 1/2 Mark) (2)

$$= \frac{100000}{10000} + 1 \quad \leftarrow$$

$$= \underline{11} \quad \checkmark$$

7.5.4 By increasing the value of Rf upward, the amount of gain achieved by the circuit is increased. ✓ This is deduced from the formula used to calculate the total gain of the circuit. ✓ (3)

Alternatively the value if Ri could be adjusted, where a small adjustment in R1 will result in a high change in gain of the circuit. ✓

7.6 Negative feedback advantages: (3)

- Improved bandwidth ✓
- Less distortion ✓

- Increased gain stability ✓
- Less noise

(any 3)

7.7

$$\begin{aligned}
 f_o &= \frac{1}{2\pi RC} && \checkmark (\checkmark = \frac{1}{2} \text{ Mark}) && (3) \\
 &= \frac{1}{2\pi(R1 + R2)(C2 + C3)} && \checkmark \\
 &= \frac{1}{2\pi(100K + 10K)(100pF + 50nF)} && \checkmark \\
 &= \frac{1}{2\pi(110000)[(100 \times 10^{-12}) + (50 \times 10^{-9})]} && \checkmark \\
 &= \frac{1}{0.0346} \\
 &= \underline{28.901Hz} && \checkmark
 \end{aligned}$$

[25]

Question 8

8.1

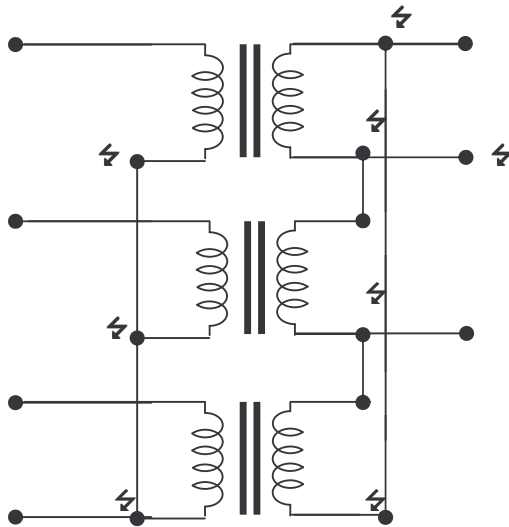

(4)

(✓ = 1/2 Mark)

8.2

- Making the transformer window long and narrow. ✓
- Arranging the primary and secondary windings ✓
- Using shell-type construction
- Sandwiching and the primary winding

(4)

(Any **TWO** correct answers)

8.3

8.3.1 $V_{2Ph} = \frac{V_{2L}}{\sqrt{3}}$ ↯ (↯ = 1/2 Mark) (2)

$= \frac{380}{\sqrt{3}}$ ↯

$= 219.4V$ ✓

8.3.2 $V_{1L} = V_{1Ph}$ (3)

$V_{1Ph} = \frac{N_1}{N_2} V_{2Ph}$ ✓

$= \frac{50}{1} \times 219.4$ ↯ (↯ = 1/2 Mark)

$= 10970V$ ↯

$\therefore V_{1L} = 10970$ ✓

8.3.3 $I_{2L} = \frac{S}{\sqrt{3}V_{2L}}$ ↯ (↯ = 1/2 Mark) (4)

$= \frac{30kVA}{\sqrt{3} \times 380}$ ↯

$= 45.58A$ ✓

$P_o = \sqrt{3}V_{2L}I_{2L} \cos \theta$ ↯ (↯ = 1/2 Mark)

$= \sqrt{3} \times 380 \times 45.58$ ↯

$= 25499W$ ✓

[15]

QUESTION 9 LOGIC CONCEPTS AND PLC'S

9.1 A PLC (i.e. Programmable Logic Controller) is a device that was invented to replace the necessary sequential relay circuits for machine control. ✓ The PLC works by looking at its inputs and depending upon their state, turning on/off its outputs. The user enters a program, usually via software, that gives the desired results. ✓ (2)

Ref: <http://www.plcs.net>

Programmable ICs also make use of instruction sets in a programme format, it does not however switch relays directly but enables multiple output and input terminals that are configured to respond in a certain manner. This allows the same PIC to be used for many different applications whereas conventional IC's have singular or limited abilities.

(Any two)

9.2 A hard wired system such as a star delta starter is wired to perform a certain duty. The system is specialized for that particular use and to alter it means to replace and rewire the system. ✓✓ (4)

In a PLC system or soft wired system, relays are wired to the PLC. All the control aspects such as timers, lockouts etc are controlled by the PLC. Changing the system now to accommodate a change in manufacturing needs or process adaptations is as easy as changing the programming that controls the relay sets. ✓✓

9.3

A PLC works by continually **scanning** a program. We can think of this scan cycle as consisting of 3 important steps. There are typically more than 3 but we can focus on the important parts and not worry about the others. Typically the others are checking the system and updating the current internal counter and timer values.

(8)

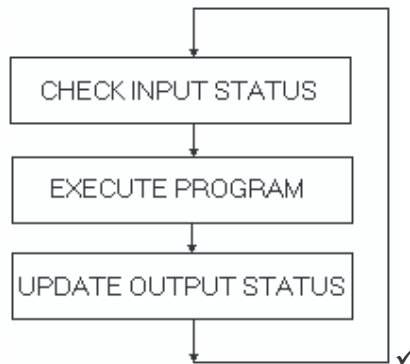

Step 1-CHECK INPUT STATUS✓-First the PLC takes a look at each input to determine if it is on or off. In other words, is the sensor connected to the first input on? How about the second input? How about the third... It records this data into its memory to be used during the next step. ✓

Step 2-EXECUTE PROGRAM✓-Next the PLC executes your program one instruction at a time. Maybe your program said that if the first input was on then it should turn on the first output. Since it already knows which inputs are on/off from the previous step it will be able to decide whether the first output should be turned on based on the state of the first input. It will store the execution results for use later during the next step. ✓

Step 3-UPDATE OUTPUT STATUS✓-Finally the PLC updates the status of the outputs. It updates the outputs based on which inputs were on during the first step and the results of executing your program during the second step. Based on the example in step 2 it would now turn on the first output because the first input was on and your program said to turn on the first output when this condition is true. ✓

After the third step the PLC goes back to step one and repeats the steps continuously. One scan time is defined as the time it takes to execute the 3 steps listed above. ✓

9.4

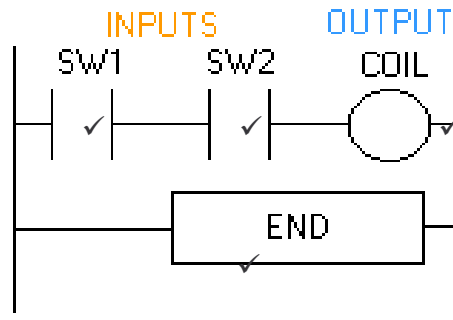

(4)

9.5

9.5.1 $A \cdot B + A' \cdot B = X$ will only partly satisfy the problem. An added memory component is needed to fully satisfy the problem. ✓✓
 A = High Level Sensor
 B = Low level Sensor
 X = Motor

9.5.2 (7)

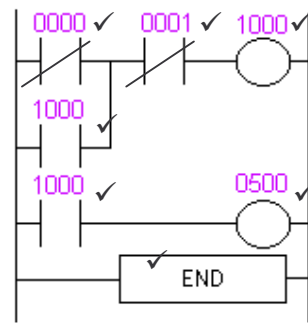

0000 – Low Level Sensor
 0001 – High Level Sensor
 1000 – Retaining Relay
 0500 – Motor

9.5.3 Addresses are assigned to inputs & outputs, morder for the PLC device to correctly identify ✓ the assigned inputs & to its programmed fuction. ✓ (2)

9.6

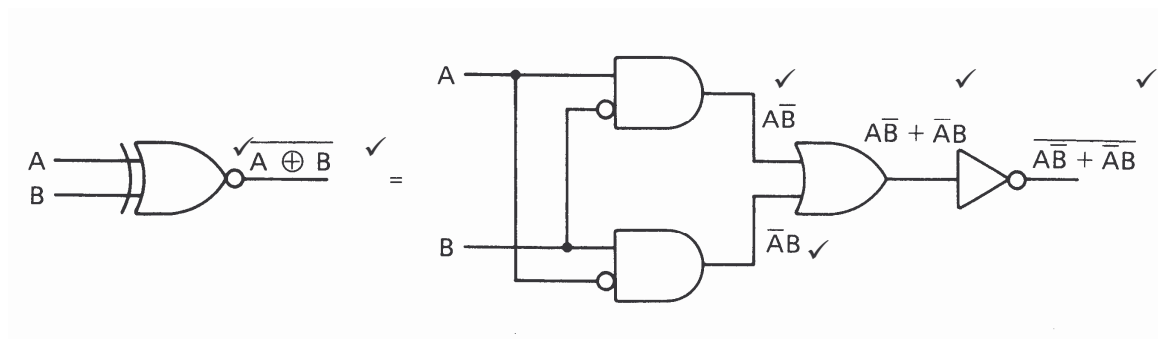

(6)

[35]

QUESTION 10
THREE PHASE MOTORS AND CONTROL

- 10.1 $Y\Delta$
At full load in Delta
 $V_L = V_{PH}$
 $I_L = \sqrt{3}I_{PH}$
 $P_{out} = 8KW$
 $P_f = 0,8$
 $\eta = 100\%$
 $V_L = 380V$
- 10.1.1 $P = \sqrt{3}V_L I_L \cos \theta$ ↯ (↯ = ½ Mark) (3)
- $$I_L = \frac{P}{\sqrt{3}V_L \cos \theta}$$
- ✓
- $$= \frac{8 \times 10^3}{\sqrt{3} \times 380 \times 0.8}$$
- ↯
- $$= \underline{15.19A}$$
- ✓
- $$I_{ph} = \frac{I_L}{\sqrt{3}}$$
- ↯ (↯ = ½ Mark) (2)
- $$= \frac{15.19}{\sqrt{3}}$$
- ↯
- $$= \underline{8.77A}$$
- ✓
- 10.1.2 $S = \sqrt{3}V_L I_L$ ↯ (↯ = ½ Mark) (4)
- $$= \sqrt{3} \times 380 \times 15.19$$
- ↯
- $$= \underline{9.997KVA}$$
- ✓
- $$S = \frac{P_{out}}{\cos \theta}$$
- ↯ (↯ = ½ Mark)
- $$= \frac{8KW}{0.8}$$
- ↯
- $$= \underline{10KVA}$$
- ✓
- 10.2 To reduce the voltage at start-up. ✓ This in turn reduces the starting current. (3)
 ✓ Reduced starting current leads to less heat build up and decreased chance of burn out. ✓
- 10.3 No-volt protection prevents a motor from restarting after a power failure. The operator needs to re-engage the start switch in order to restart the motor. This protects both the operator and the equipment. ✓✓✓✓ (4)
- 10.4 A normally closed contact is closed in a de-energised state and opens in an energized state? ✓✓✓✓ (4)
- 10.5 Swap the connections to any of the three phases. ✓ (1)

- 10.6
- A three –phase voltage supply is connected across the stator windings✓
 - This sets up a three phase alternating current system in the windings✓.
 - A rotating magnetic field is created in the stator due to the flow of the 3-phase current each at an angle of 120° out of phase with each other✓.
 - The rotating magnetic field sweeps across the squirrel cage of the rotor and an EMF is induced in the rotor. Causing current to flow in the squirrel cage. ✓
 - The induced current in the squirrel cage generates a magnetic field which interacts with the rotating magnetic field from the stator. ✓
 - The magnetic fields try to conform and as a result the rotor is turned due to the forced exerted on it. ✓
 - The two magnetic fields interact and as soon as the rotor field tends to reach the synchronous speed the induced current is reduced and the rotor speed lags behind the rotating magnetic field. This lag is known motor slip and cannot be overcome unless the rotor field is energized additionally with a DC current, converting it to a synchronous motor✓✓.
- 10.7 Earthing the enclosure of the motor will keep it at earth potential ✓, thus preventing it from becoming live / hot and placing the life of the operator in danger. This precautionary measure ensures the safety of the worker. (1)

[30]**Total [200]**